

WOODRUFF KEY SEAT CUTTER

Cutting Rake - 20°
for positive TEHW inserts

Milling Application

Finishing	Medium	Roughing
Best	Good	Average

Insert Type

Steel	Stainless Steel	Cast Iron	Aluminum	High Temper Alloy
TEHW-EN	TEHW-EN	TEHW-EN	TEHW-EN	TEHW-EN

For insert information see pages E-76 to E-77.

Milling
Technical Data

Milling Inserts

Milling
Toolholder (Inch)

Milling
Toolholder (Metric)

Milling
Spare Parts

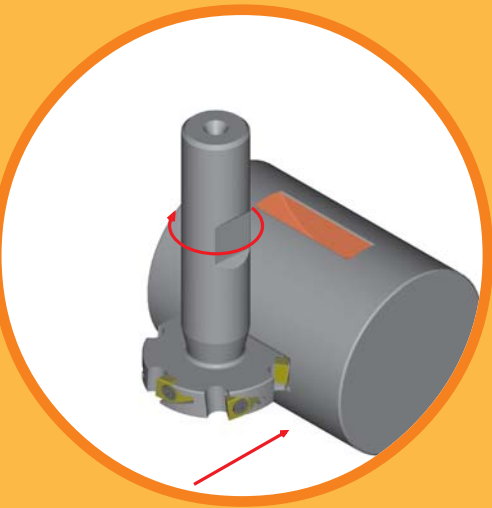

TOOL ANGLES:

- Cutting Rake 20°
- Axial Rake +/- 6°
- Radial Rake -10°

FEATURES:

- Available in 1/2" Weldon shank size
- High rate of material removal
- Staggered tooth design
- Torx screw locking system



Operation	Tool Rotation	Direction of Cut
Woodruff Key Seat	Right Hand	Horizontal

American Standard Size	Description	Part No. 733101-	C	D	d	F	No. Inserts	TEHW Gage Insert	Insert Torx Screw	Torx Key
606	DWKC-606-TE06-050	65140	2.188	.750	.500	.188	2			
806	DWKC-806-TE06-050	65141	2.250	.750	.500	.250	2	0602	TS-06	T-6
607	DWKC-607-TE06-050	65142	2.188	.875	.500	.188	2			
707	DWKC-707-TE06-050	65143	2.219	.875	.500	.219	2	0602	TS-06	T-6
807	DWKC-807-TE06-050	65144	2.250	.875	.500	.250	2			
608	DWKC-608-TE06-050	65145	2.188	1.000	.500	.188	3			
708	DWKC-708-TE06-050	65146	2.219	1.000	.500	.219	3			
808	DWKC-808-TE06-050	65147	2.250	1.000	.500	.250	3	0602	TS-06	T-6
1008	DWKC-1008-TE06-050	65148	2.313	1.000	.500	.313	3			
1208	DWKC-1208-TE06-050	65149	2.375	1.000	.500	.375	3			
609	DWKC-609-TE06-050	65150	2.188	1.125	.500	.188	4			
709	DWKC-709-TE06-050	65151	2.219	1.125	.500	.219	4			
809	DWKC-809-TE06-050	65152	2.250	1.125	.500	.250	4	0602	TS-06	T-6
1009	DWKC-1009-TE06-050	65153	2.313	1.125	.500	.313	4			
610	DWKC-610-TE06-050	65154	2.188	1.250	.500	.188	6			
710	DWKC-710-TE06-050	65155	2.219	1.250	.500	.219	6			
810	DWKC-810-TE06-050	65156	2.250	1.250	.500	.250	6	0602	TS-06	T-6
1010	DWKC-1010-TE06-050	65157	2.313	1.250	.500	.313	6			
1210	DWKC-1210-TE06-050	65158	2.375	1.250	.500	.375	6			
811	DWKC-811-TE06-050	65159	2.250	1.375	.500	.250	6			
1011	DWKC-1011-TE06-050	65160	2.313	1.375	.500	.313	6	0602	TS-06	T-6
1211	DWKC-1211-TE06-050	65161	2.375	1.375	.500	.375	6			
812	DWKC-812-TE06-050	65162	2.250	1.500	.500	.250	6			
1012	DWKC-1012-TE06-050	65163	2.313	1.500	.500	.313	6	0602	TS-06	T-6
1212	DWKC-1212-TE06-050	65164	2.375	1.500	.500	.375	6			

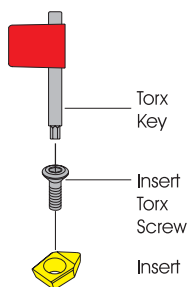
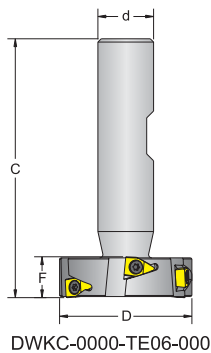

For spare part information see page E-177.